



Electric scooter professional use

User manual

Welcome to the electric era!

Thank you for having chosen a more sustainable mobility which makes air more breathable with lower consumption and great savings, as well as guaranteed autonomy; a way to do good to yourself and the planet.

Congratulations for having decided to embrace a new lifestyle and innovative thinking: using cutting-edge technology such as electricity can only have positive effects.

Acquiring Askoll eS_{pro} 45, eS_{pro} 25Km/h or eS_{pro} 70, you will finally enjoy a mean that concentrates the best of Askoll functionality, design and technology, a company with thirty years of experience in the design and manufacture of electric engines.

This manual has been prepared to allow you to fully appreciate its quality. It contains information, warnings and advice on the proper use and maintenance of your new vehicle.

It is important to read it entirely before driving your vehicle for the first time. You will find out details and features that will reassure you of the choice made.

This publication is to be considered an integral part of the vehicle. If the vehicle is sold, the manual must be delivered to the new owner.

EN

The constant evolution in the design, aimed to guarantee the safety and quality standards of Askoll vehicles, may result in the fact that some information contained in this Use and Maintenance Handbook can be different from the vehicle in your possession. We are therefore confident that you will understand that the data, figures and descriptions herein may not be grounds for any claims.

INDEX

INDEX	II
GENERAL INFORMATIONS	1
SYMBOLS	1
SAFETY IMPORTANT INFORMATION	2
IDENTIFICATION	3
CONTROLS AND INSTRUMENTS	4
SCOOTER OVERVIEW	4
eS _{pro} 45 - eS _{pro} 25Km/h LEFT SIDE	4
eS _{pro} 45 - eS _{pro} 25Km/h RIGHT SIDE	4
eS _{pro} 70 LEFT SIDE	5
eS _{pro} 70 RIGHT SIDE	5
CONTROLS AND INSTRUMENTS POSITION	6
DASHBOARD (eS _{pro} 45 - eS _{pro} 25Km/h)	6
DASHBOARD (eS _{pro} 70)	7
LH CONTROLS	8
Rear brake lever	8
Drum brake lever with combined function (eS _{pro} 70 only)	8
Power regeneration switch	8
Turn indicators switch	9
Horn	9

RH CONTROLS	10
Front brake lever	10
Throttle control	10
Headlight high beam light ON/OFF selector (eS _{pro} 70 only)	11
Driving mode switch (eS _{pro} 45 - eS _{pro} 70 only)	11
Engine start switch	11
KEY SWITCH	12
Enabling and disabling the system	12
INSTRUMENT PANEL	13
WARNING LIGHTS	14
Engine enabling warning light (eS _{pro} 45 - eS _{pro} 25Km/h only)	14
Temperature warning light	15
Serious problem warning light	15
Operating turn indicators warning light	16
Lights warning light	16
High beam light indicator (eS _{pro} 70 only)	16
Charging warning light	16
SPEEDOMETER (eS_{pro} 45 - eS_{pro} 25Km/h)	17
SPEEDOMETER (eS_{pro} 70)	17
MENU SETTING BUTTONS	17
DIGITAL DISPLAY	18
Maintenance warning light	18

INDEX

USE	19
CHECKS BEFORE DEPARTURE	19
SAFE DRIVING	19
OPERATIONS TO START	21
Steering lock engagement	21
Engine enabling	22
Driving mode selection (eS _{pro} 45)	23
Driving mode selection (eS _{pro} 70)	24
Power regeneration selection	25
SELECTION OF DISPLAY FUNCTIONS	26
Odometer data display mode	26
Setting the clock	27
SEAT	28
Opening the seat	28
Bag hook	28
PARKING THE SCOOTER	29
BATTERIES AND RECHARGE	30
BATTERIES	30
Battery management in the first use of the scooter	30
Disposal of exhausted batteries	32

BATTERY CHARGER	33
CHARGING THE BATTERIES	35
CHARGING WITH BATTERY ON BOARD	36
Locking the seat in raised position for cable passage	37
CHARGING WITH BATTERY OUTBOARD	39
ADJUSTMENTS AND PERIODIC MAINTENANCE	43
ADJUSTMENTS	43
REAR VIEW MIRRORS	43
HEADLAMP	43
FRONT DISC BRAKE	44
REAR BRAKE DRUM (eS_{pro} 45 - eS_{pro} 25Km/h)	45
REAR DRUM BRAKE WITH COMBINED FUNCTION (eS_{pro} 70 only)	45
ORDINARY MAINTENANCE PROCEDURES	46
TYRES	46
FRONT BRAKE FLUID LEVEL CONTROL	47
HEADLAMP BULB REPLACEMENT (eS_{pro} 45 - eS_{pro} 25Km/h)	48
HEADLIGHT (eS_{pro} 70)	49
TAIL LIGHTS AND TURN INDICATORS	50
ORDINARY MAINTENANCE PROCEDURES TABLE	51
CLEANING THE VEHICLE	52
VEHICLE INACTIVITY	53





INDEX

ERROR CODES	54
ERROR CODES	54
TECHNICAL DATA	57
SCOOTER DIMENSIONS eS_{pro} 45 - eS_{pro} 70 - eS_{pro} 25Km/h	57
ENGINE DATA	58
BATTERY	58
VEHICLE DATA	58
HEADLIGHT DATA	59
TAIL LIGHT DATA	59
DECLARATION OF CONFORMITY	LX

SYMBOLS

This manual contains particularly important information that should be read with care.

Each signal consists of a different symbol to make clear the content of the text that follows it, and to facilitate the placement of the subjects in the different areas.

 CAUTION	This symbol indicates situations of particular danger, which could result in death or serious injury if not avoided.
 WARNING	This symbol indicates a security generic warning. It is used to put warn about potential danger of personal injury or damage to things.
	Failure to fully comply with these requirements may cause serious damage to the vehicle and in some cases void the warranty.
	Right behaviour is indicated to prevent damaging nature by using the vehicle.

GENERAL INFORMATIONS

SAFETY IMPORTANT INFORMATION



It is very important for you to know the electric scooter: read and understand this manual before the first use.



This operating manual is part of the scooter, keep it for future reference. If the scooter is sold, the manual must be delivered to the next owner.



The scooter is not intended to be used by persons with reduced physical, sensory or mental capacities, or lack of experience or knowledge, unless a person responsible for their safety has supervised or instructed them concerning the use of the scooter.



Failure to fully comply with these requirements may cause serious damage to people, the vehicle, the environment and in some cases void the warranty.



Each processing that changes either performance or main structure of the scooter, besides from being forbidden by law, void vehicle compliance and approvals, making it dangerous.

IDENTIFICATION

Identification plates are stamped on frame, engine casing and battery compartment. They must be indicated when ordering spare parts.

It is advisable to check the correspondence of vehicle plates with the ones present in its documents.

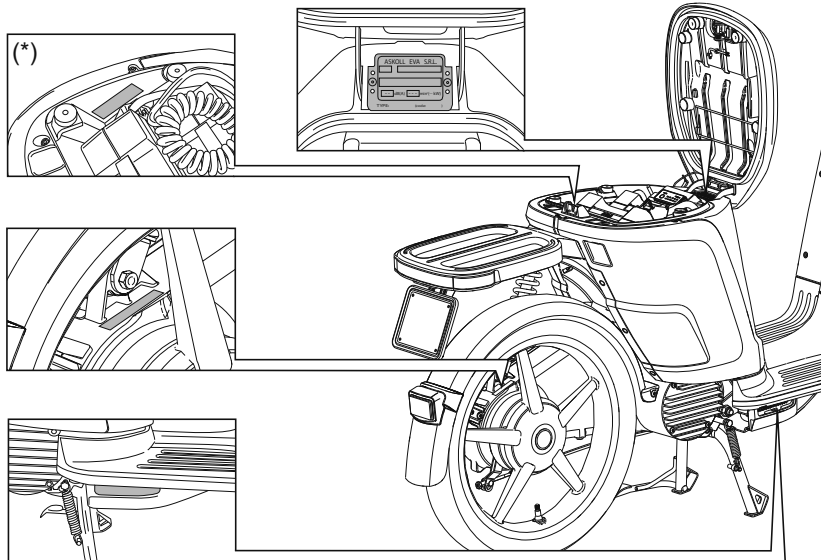

(*) Valid only for eS_{pro} 45 - eS_{pro} 25Km/h. Not required for eS_{pro} 70.

 **WARNING**



Alteration of identification plates can incur in serious penalties.

CONTROLS AND INSTRUMENTS

SCOOTER OVERVIEW

eS_{pro} 45 - eS_{pro} 25Km/h LEFT SIDE

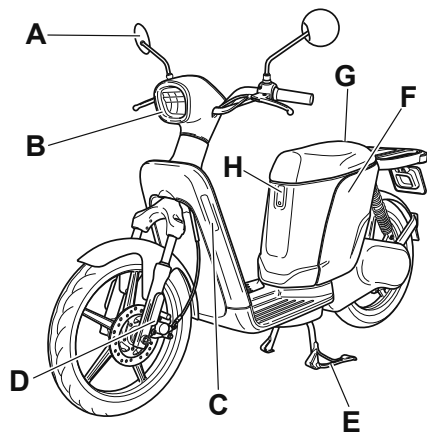

- A. Rear view mirror
- B. Headlights
- C. Turn indicator
- D. Front LH reflector
- E. Stand
- F. Battery compartment
- G. Seat

eS_{pro} 45 - eS_{pro} 25Km/h RIGHT SIDE

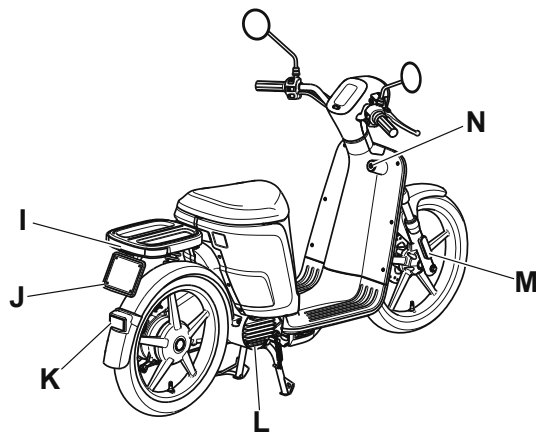

- H. Seat hook
- I. Tail light
- J. License plate holder
- K. Rear reflector
- L. Engine
- M. Front RH reflector
- N. Ignition switch

SCOOTER OVERVIEW

eS_{pro} 70 LEFT SIDE

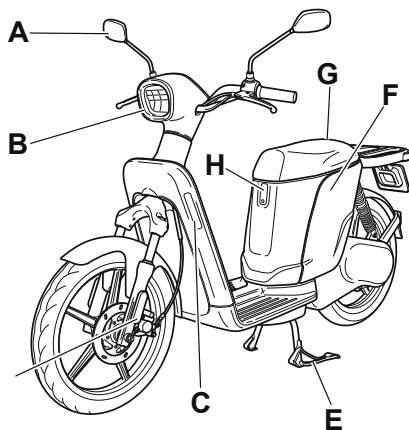

- A. Rear view mirror
- B. Headlights
- C. Turn indicator
- D. Front LH reflector
- E. Stand
- F. Battery compartment
- G. Seat

eS_{pro} 70 RIGHT SIDE

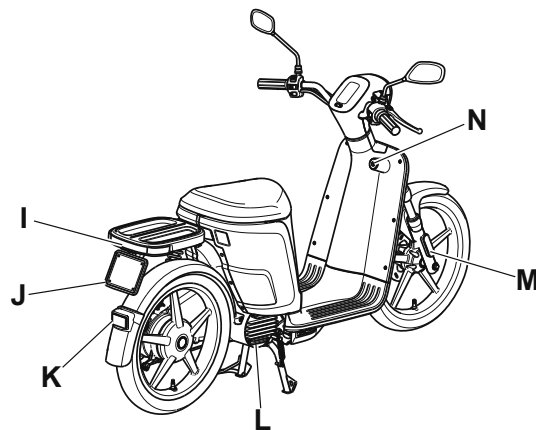

- H. Seat hook
- I. Tail light
- J. License plate holder
- K. Rear reflector
- L. Engine
- M. Front RH reflector
- N. Ignition switch

CONTROLS AND INSTRUMENTS

CONTROLS AND INSTRUMENTS POSITION

DASHBOARD (eS_{pro} 45 - eS_{pro} 25Km/h)

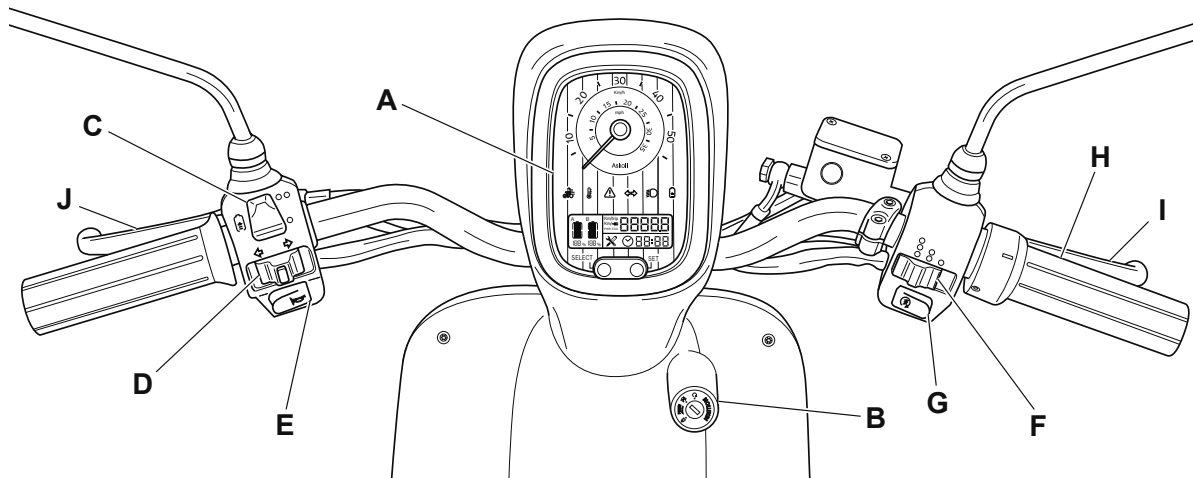

- A. Instrument panel
- B. Key switch
- C. Power regeneration switch
- D. Turn indicators switch
- E. Horn

- F. Driving mode switch
- G. Engine start switch
- H. Throttle control
- I. Front brake lever
- J. Rear brake lever

CONTROLS AND INSTRUMENTS POSITION

DASHBOARD (eS_{pro} 70)

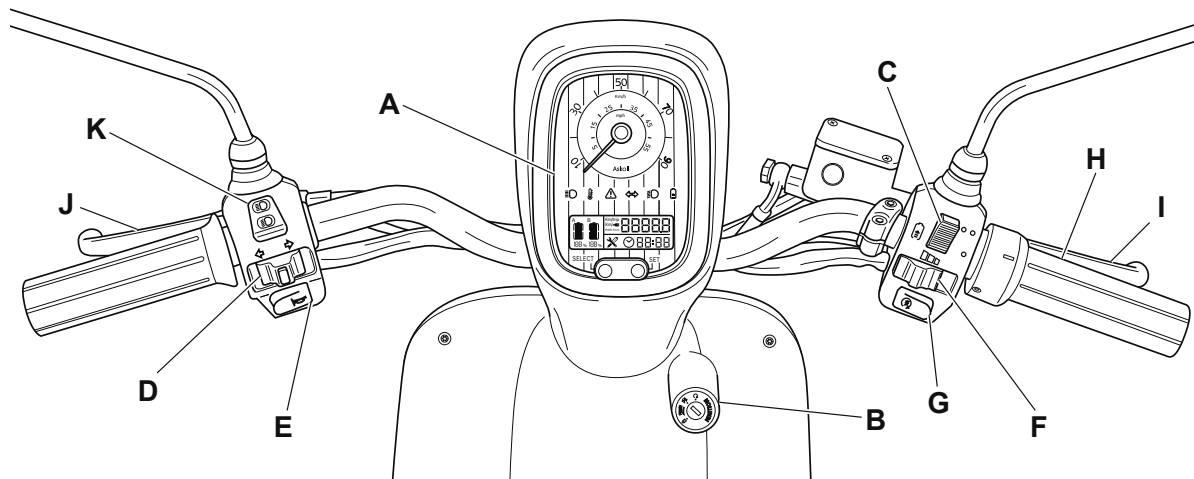

EN

A. Instrument panel

B. Key switch

C. Power regeneration switch

D. Turn indicators switch

E. Horn

F. Driving mode switch

G. Engine start switch

H. Throttle control

I. Front brake lever

J. Combined brake control lever

K. Headlight switch

CONTROLS AND INSTRUMENTS

LH CONTROLS

Rear brake lever

Rear drum brake lever is placed on the left side of the handlebar.

Drum brake lever with combined function (eS_{pro} 70 only)

The brake acts on both wheels, with prevalence on the rear one to ensure greater safety and improved stopping distances.

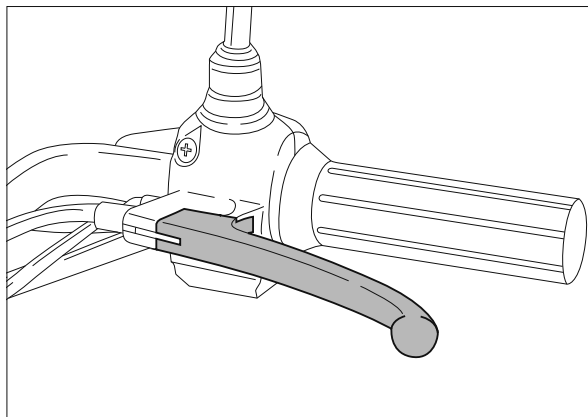

Power regeneration switch

During scooter deceleration, the battery can be automatically recharged by activating the power regeneration mode.

Use the 2 position turn indicators switch to activate or deactivate power regeneration.

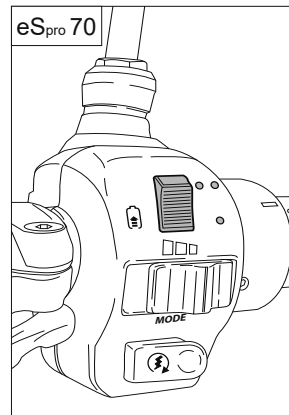
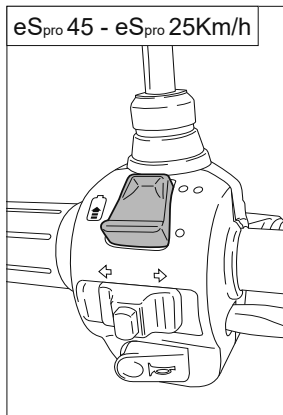

Turn indicators switch

Move the lever to the left to operate LH turn indicator.

Move the lever to the right to operate RH turn indicator.

Press the button in the centre of the lever to turn the indicators off.

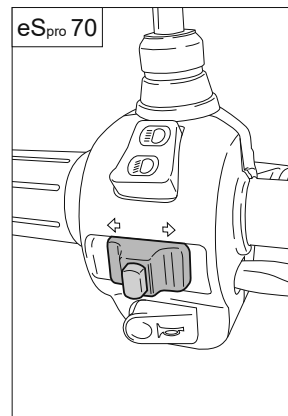
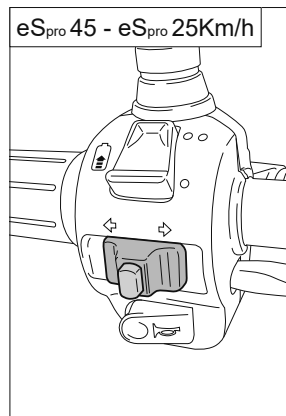

Horn

Press to honk the horn.

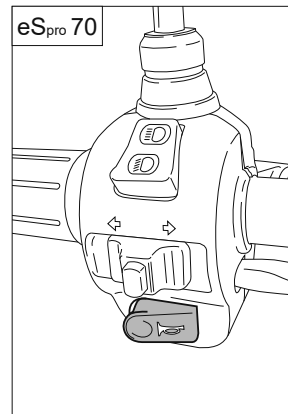
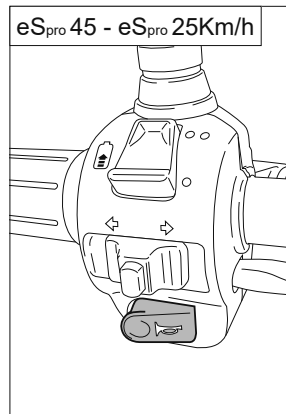

CONTROLS AND INSTRUMENTS

RH CONTROLS

Front brake lever

Front disk brake lever is placed on the right side of the handlebar.

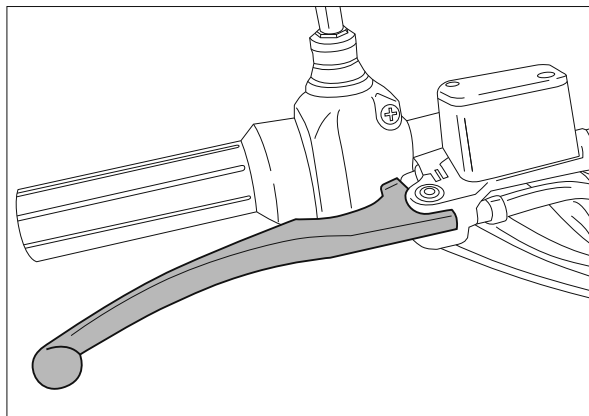

Throttle control

Scooter speed is adjusted through the grip.

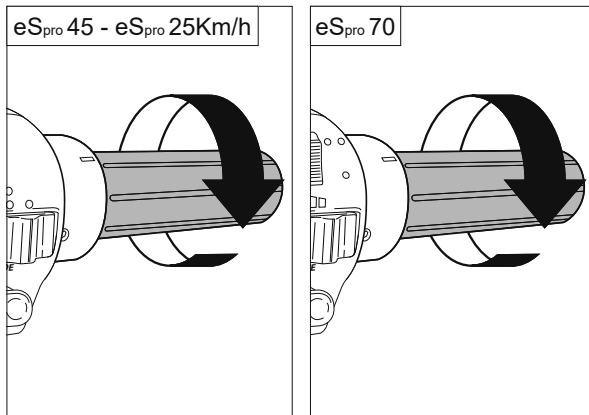

Headlight high beam light ON/OFF selector (eS_{pro} 70 only)

Using the selector is possible to activate the high beam light.

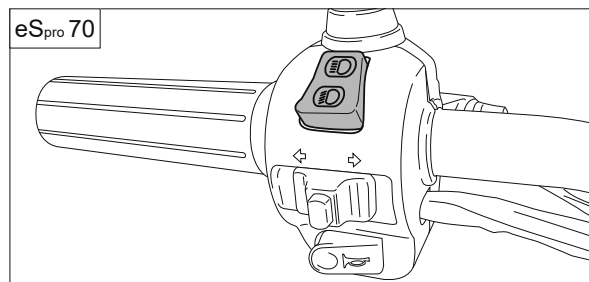

Driving mode switch (eS_{pro} 45 - eS_{pro} 70 only)

Three different driving modes can be selected using the switch depending on driving style, road conditions or other.

The eS_{pro} 25Km/h model has a single driving mode and its speed is limited to 25 Km/h.

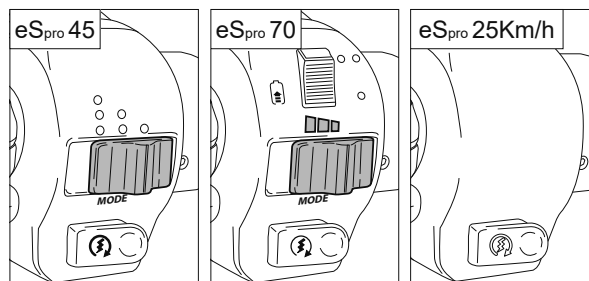

Engine start switch

Pressing the button for 3 seconds will start or stop the engine depending on key position.

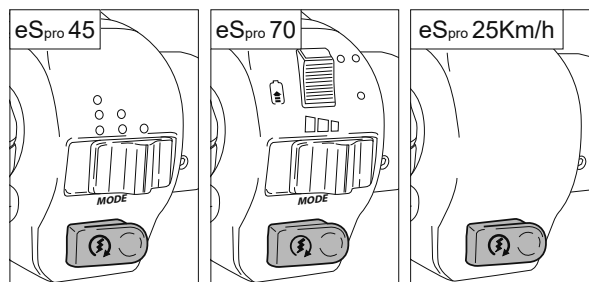

CONTROLS AND INSTRUMENTS

KEY SWITCH

The key switch enables or disables system and steering lock.

The scooter is provided with a main key and a duplicate, both can be used to actuate the key switch and to open the seat.

Please, keep the duplicate key separated from the main one.

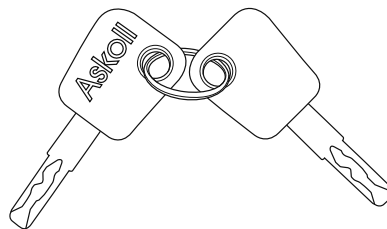

Enabling and disabling the system

Turning the key to  the system enables.

Turning the key to  the system disables.

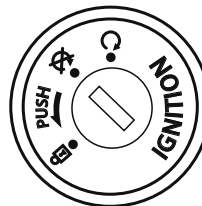

WARNING

Do not turn or remove key while driving.

INSTRUMENT PANEL

eS_{pro} 45 - eS_{pro} 25Km/h

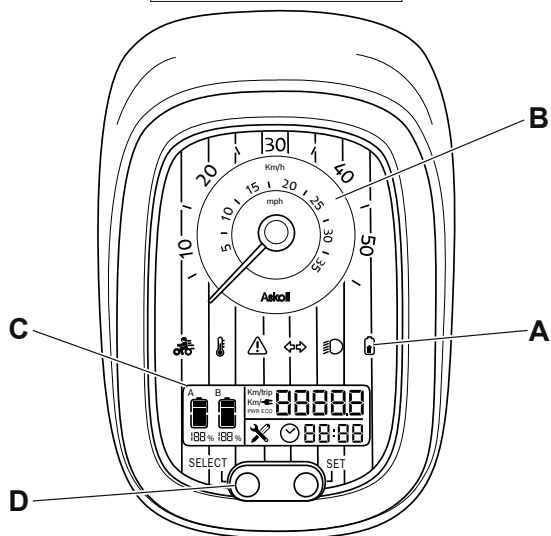

eS_{pro} 70

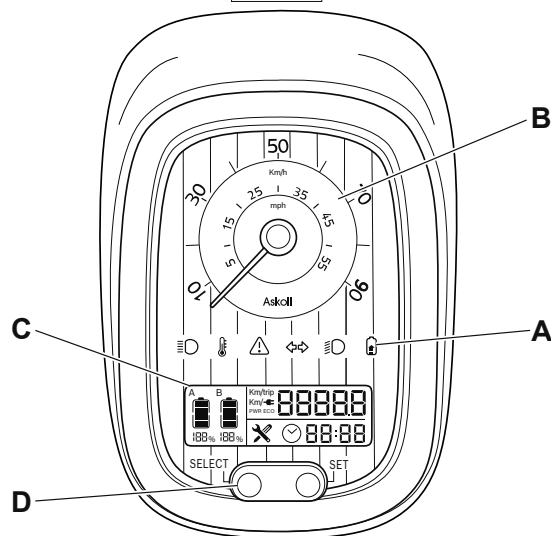

- A. Warning lights
- B. Speedometer
- C. Digital display
- D. Display controls

CONTROLS AND INSTRUMENTS

WARNING LIGHTS

- E. Engine enabling warning light
- F. Temperature warning light
- G. Serious problem warning light
- H. Operating turn indicators warning light
- I. Lights warning light
- J. Charging warning light
- K. High beam light ON indicator (eS_{pro} 70 only)



E



F



G



H



I



J



K

Engine enabling warning light (eS_{pro} 45 - eS_{pro} 25Km/h only)

The warning light indicating that the engine is enabled is amber, it turns on as soon as the engine is enabled and remains on until it is disabled.



Temperature warning light

The warning light indicating high temperature is amber, it turns on and remains on to indicate an overtemperature alarm. Its alarm code can be read on the display.

Alarm description regarding displayed code is explained in “**ERROR CODES**” chapter.



EN

Serious problem warning light

Serious problem warning light is red, it turns on together with the malfunction one.

Stop the vehicle when it turns on and read the error code on the display.

It is necessary to go to an authorized workshop to have the vehicle checked.

Alarm description regarding displayed code is explained in “**ERROR CODES**” chapter.



CONTROLS AND INSTRUMENTS

Operating turn indicators warning light

Turn indicators warning light is green, it turns on and blinks to indicate RH or LH activation and it turns off when they are deactivated.



Lights warning light

Lights warning light is green, it turn on when engine is enabled.



High beam light indicator (eS_{pro} 70 only)

The high beam light indicator is blue, it is turned on by actuating the selector on the left stalk.



Charging warning light

Charging warning light is amber, it turns on and remains on when the battery charger is connected and batteries are being charged. It also turns on when power regeneration is active.



SPEEDOMETER (eS_{pro} 45 - eS_{pro} 25Km/h)

Speedometer indicates current speed.

The value is displayed in kilometres per hour (km/h) and miles per hour (mph).

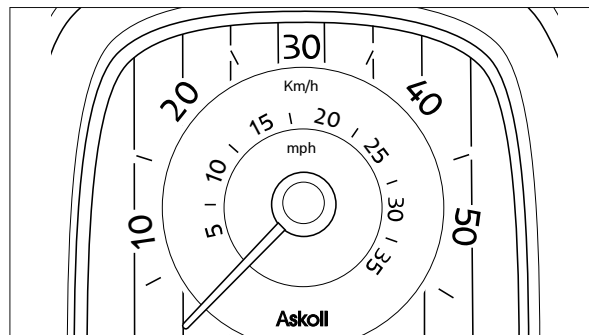

SPEEDOMETER (eS_{pro} 70)

Speedometer indicates current speed.

The value is displayed in kilometres per hour (km/h) and miles per hour (mph).

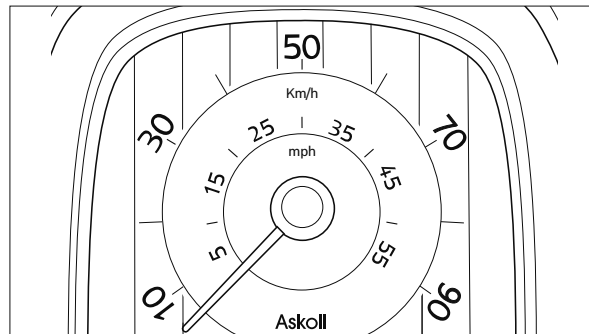

MENU SETTING BUTTONS

SELECT and **SET** buttons must be used to:

- select the parameter to display,
- reset displayed value (km/trip),
- set and confirm new values (hour).

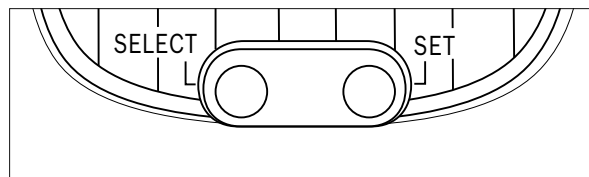

CONTROLS AND INSTRUMENTS

DIGITAL DISPLAY

On the digital display it is possible to have all the information regarding vehicle status, namely:

- battery presence on A and B compartments,
- battery charge,
- total mileage,
- partial mileage,
- mileage to go with remaining battery charge,
- time,
- alarms and their error codes.

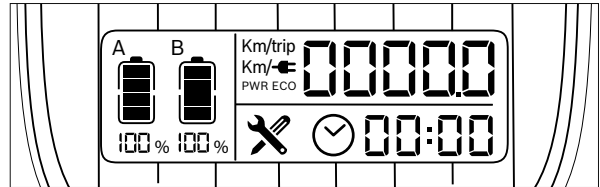

Maintenance warning light

Maintenance warning light can light by itself or together with Serious problem warning light.

If it turns on, it is advisable to take the vehicle to an Authorized Dealer to have the problem controlled and solved.









CHECKS BEFORE DEPARTURE

Before using the scooter, it is always good practice to carry out certain controls:

- check battery charge,
- check headlight, tail light, turn indicators and number plate light operation,
- check front and rear brakes operation,
- check fluid level in front brake reservoir,
- check tire pressure,
- check that the seat is not raised and locked and that charger cables are properly placed in the battery compartment.

To properly carry out these controls, refer to the instructions in this manual.

SAFE DRIVING

 WARNING	Before the first use, we suggest you to try the scooter in areas closed to traffic until you familiarise yourself with it.
 WARNING	Always ride within the limits of your abilities.
 CAUTION	Riding under the influence of alcohol, drugs or certain medicines is dangerous and it is prohibited by law.
 WARNING	Before you start riding, always wear a helmet and fasten it correctly.
 WARNING	If you are carrying a passenger, before starting to drive check that he has worn the helmet and that it is correctly fitted and fastened.
 WARNING	Recommend the passenger to always remain firmly attached to the appropriate grab handle while traveling.
 WARNING	Avoid departing with the centre stand down: when the rear wheel makes contact with the ground, it should not turn to avoid abrupt departure.

USE



Drive very carefully on bumpy, wet, snowy or slippery roads, it will be necessary to reduce speed and increase safety distance from other vehicles.



Use both brakes to allocate braking action on both wheels.



Do not brake hard on wet, slippery or dirt roads.



If travelling on a wet road for some time without actuating the brakes, initially there will be less braking action. Under these conditions, periodically actuate the brakes.



In case of rain visibility decreases, so reduce speed and drive carefully.

OPERATIONS TO START

Steering lock engagement

To engage the steering lock, turn the handlebar left until it stops.

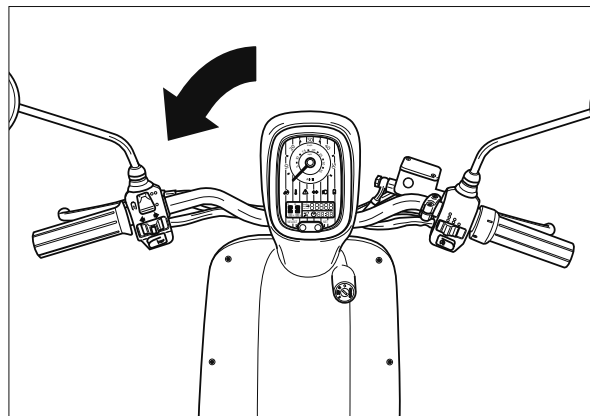

Press the key inwards and turn counterclockwise; while turning the handlebar slightly clockwise until the key is on the lock; now the steering lock is inserted and you can remove the key.

To disengage the steering lock, insert the key into the ignition switch and turn it right.

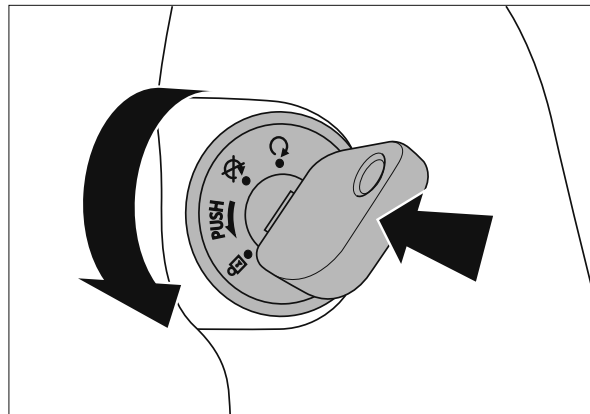



USE

Engine enabling

The engine must be enabled to start.

To enable the engine, insert the key into the switch and turn it to , then press for 3 seconds to enable the engine, motion warning light will turn on.

To disable the engine, press the engine enabling button again for 3 seconds and turn the key in the ignition switch to the left on .

The engine will be disabled also by rotating the key to .

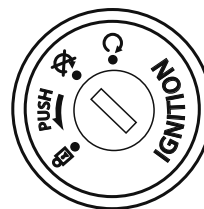
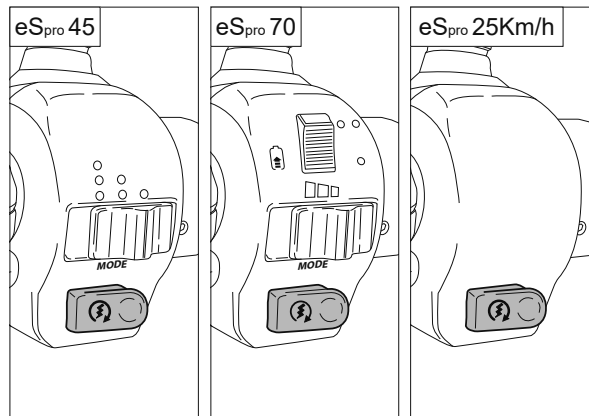

Driving mode selection (eS_{pro} 45)

Three different riding modes can be selected through the ignition switch:

- Mode **ECONOMY**
 - Max speed: 32 Km/h.
 - ECO icon appears on the display.
- Mode **NORMAL**
- Max speed: 37 Km/h.
- No icon appears on the display.
- Mode **POWER**
- Max speed: 45 Km/h.
- PWR icon appears on the display.

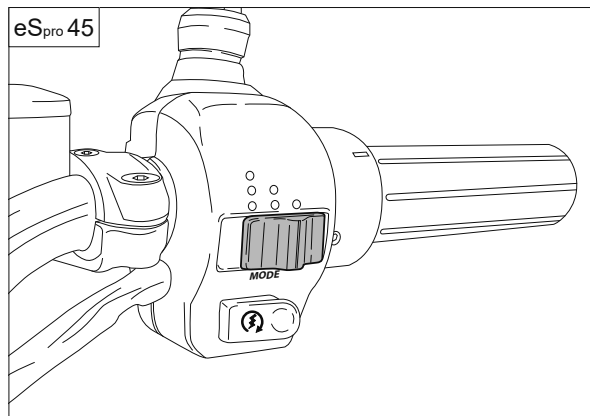

The eS_{pro} 25Km/h model has a single driving mode and its speed is limited to 25 Km/h.

eS_{pro} 45 version: autonomy 71 Km*

eS_{pro} 25Km/h version: autonomy 86 Km*

* according to regulation 168/2013 EC.

The autonomy values listed above are valid with the use of 2 batteries connected and with the same charging value.



WARNING

Lithium-ion batteries undergo a progressive performance decay that reduces the initial autonomy values.



WARNING

The autonomy data indicated depend strictly on the conditions of use, which may be: slope and/or type of road surface, ambient temperature, average speed, motor assistance level, tire pressure, weight carried and user's weight, age of batteries.

USE

Driving mode selection (eS_{pro} 70)

Using the switch it is possible to select three different driving modes:

ECONOMY mode

NORMAL mode

These modes are used to minimize consumption.

POWER mode

Full speed: 67 Km/h.

The PWR icon appears on the display

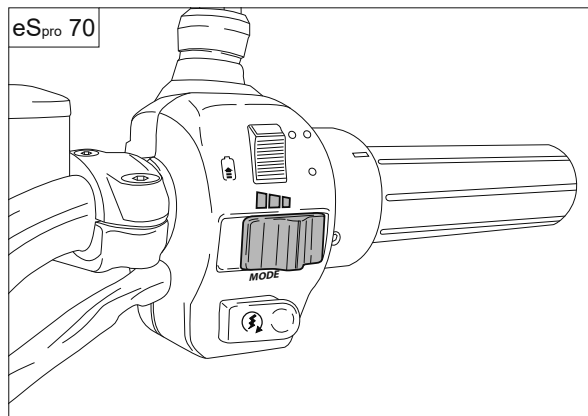

Autonomy 96 Km according to regulation 168/2013 EC.

The autonomy values listed above are valid with the use of 2 batteries connected and with the same charging value.



WARNING

Lithium-ion batteries undergo a progressive performance decay that reduces the initial autonomy values.



WARNING

The autonomy data indicated depend strictly on the conditions of use, which may be: slope and/or type of road surface, ambient temperature, average speed, motor assistance level, tire pressure, weight carried and user's weight, age of batteries.

Power regeneration selection

During scooter deceleration, the battery can be automatically recharged by activating the power regeneration mode.

Use the 2 position turn indicators switch to activate or deactivate power regeneration:

- Pressing the button upwards, power regeneration mode is activated and deceleration increases.

- Pressing the button downwards, power regeneration mode is deactivated.

Combining braking with deceleration, charging will be greater.

When power regeneration mode is activated, charging warning light is on.

With a high level of battery charge, power regeneration mode is not activated.

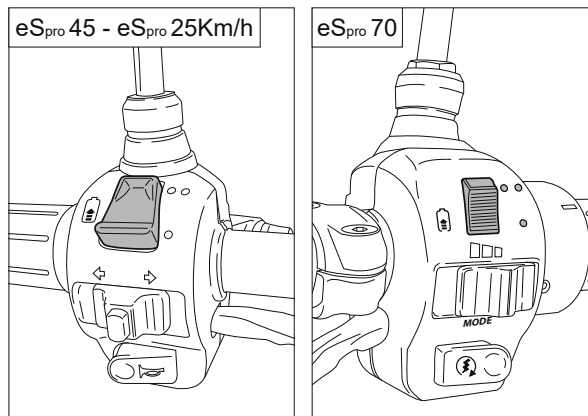

USE

SELECTION OF DISPLAY FUNCTIONS

Odometer data display mode

Upon power up, all display lights will remain lit for a few seconds.

Press **SELECT** to change the parameter on the display:

- Km** Total mileage.
The parameter cannot be modified.
- Km/trip** Partial mileage.
Keep SET pressed to zero during parameter display.
- Km/⚡** Mileage to go with remaining battery charge. The value varies depending on the conditions of use, remaining battery charge, driving mode set and power regeneration mode selected.

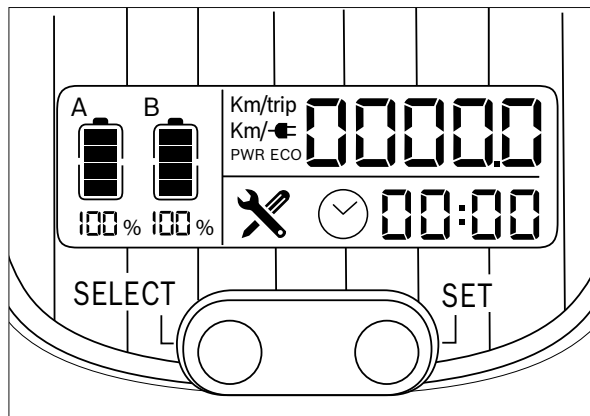

Setting the clock

- Press and hold **SELECT** button for 2 seconds: two hour digits will start blinking.
- Press **SELECT** as necessary to set the right hour.
- Press **SET**: minutes digits will start blinking while hour digits will not blink any more.
- Press **SELECT** as necessary to set the right minutes.
- Press **SET** button to exit.

Since time is stored in the vehicle battery, in case of two batteries, it is convenient to set the clock with both batteries installed to synchronize time. In the presence of two batteries, time displayed is the one stored in compartment **A**.

For battery description and placement in compartments **A** and **B** refer to the chapter “**BATTERY AND CHARGE**”.

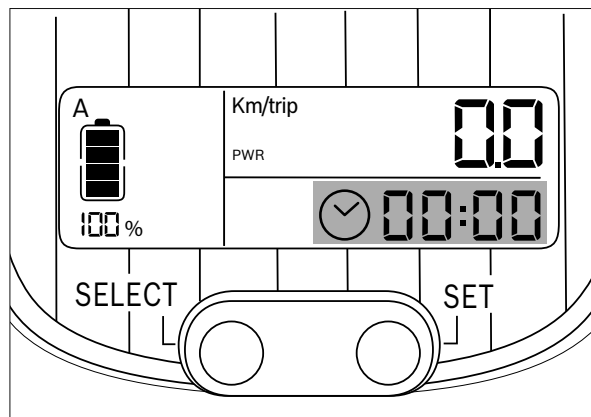

USE

SEAT

Opening the seat

Insert the key into the lock on the rear left.

Turn clockwise.

Tilt the seat forward.

While closing, the seat lock will automatically lock.

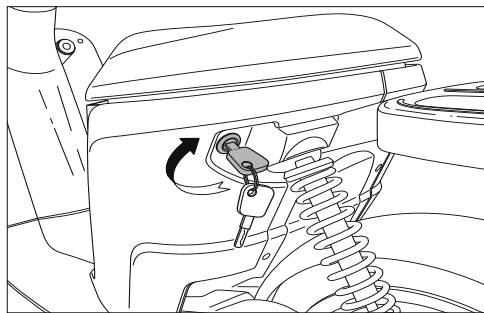

Bag hook

The bag hook is located between the seat and the footrest.

Pressing on the bottom of the hook, the upper part comes out and it is possible to hang an object.

Releasing the hook, it will automatically return to its seat.

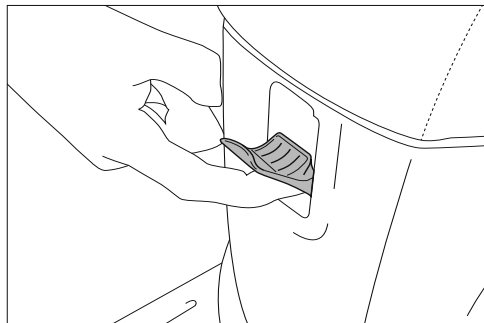

WARNING

The object carried should not tamper or restrict movement of the legs.



WARNING

Avoid placing all the weight on the hook, the object carried should also rest on the platform.

PARKING THE SCOOTER

Use the stand to park.

Lower the kickstand with your foot until the opening is complete and simultaneously lift the scooter manually, grabbing the luggage rack with your right hand and accompanying it until the scooter is fully supported.

⚠ WARNING Pushing the scooter forward the kickstand automatically returns to the starting position: **this operation must always be performed before getting on the scooter.**

⚠ WARNING Avoid sitting on the scooter when it is parked on the stand.

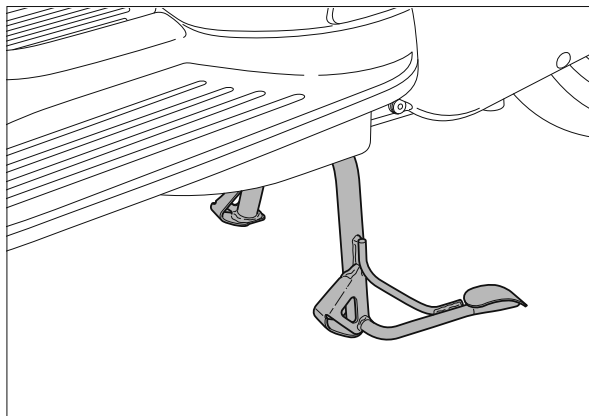

WARNING

Use the stand on compact and flat surfaces.



WARNING

Pay attention to manoeuvring when parked, in particular when placing the scooter on the stand so that the vehicle does not fall.

BATTERIES AND RECHARGE

BATTERIES

The vehicles eS_{pro} 45, eS_{pro} 25Km/h and eS_{pro} 70 contain two lithium-ion batteries. The eS_{pro} 45 and eS_{pro} 25Km/h models are equipped with batteries model TVC102, while the model eS_{pro} 70 is equipped with batteries model TVC103.

The two batteries are housed in the two compartments **A** and **B** located under the seat.

Weight of each battery: 7.6 kg.

Internal temperature of the battery while charging: From +10 °C to +45 °C.

There may be autonomy reduction at low temperatures.

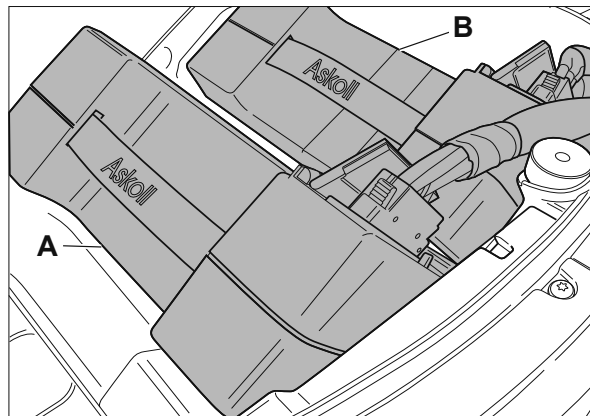

The battery is an always active component, it may show light voltage drops even with the control panel off.

Battery management in the first use of the scooter







With new batteries it is necessary to perform at least 3 - 4 complete charging/discharging cycles, bringing the charge to 100% and discharging the battery at a value close to 0%, this allows you to properly align the batteries in the first period of use.



If the scooter remains off for a long period at low temperatures (0 to 10°C), recharging might take longer.



If the scooter is not used for a long period of time, recharge the batteries at least every three months and until 50% (MODE - MAINTENANCE)

	Never disconnect wires from the electrical system with engine running so as to prevent battery damage.
	Disassembling and/or tampering with the batteries will make the warranty void.
	Respecting the environment, at the end of their life cycle, batteries must be collected and disposed of according to law.
 CAUTION	Do not use this battery for purposes other than those indicated. Use other than intended could result in short circuit within the battery which could catch fire.
 CAUTION	<p>Fire hazard</p> <ul style="list-style-type: none">• Do not disassemble or brake the battery.• As a result of an accident with serious mechanical damage to the battery, there could be short circuits within the battery itself and it may be damaged or catch fire.• In case of an accident leave the vehicle outdoors for about an hour at a safe distance from any flammable material. With a finger touch the battery briefly and cautiously. If you sense an unusually high temperature, leave your vehicle where it is. Do not continue using it for any reason. As soon as the battery has cooled, take the vehicle to your dealer.• In the presence of flames or smoke rising from the battery, stop the vehicle immediately. Then turn off the fire with a fire extinguisher, if available. If a fire extinguisher is not available, wait until the fire has extinguished and all parts of the vehicle have cooled down. If there is a risk that the fire spreads to nearby objects, notify the Fire Department.
 WARNING	After charging and before removing the batteries, disconnect the power plug of the charger from the socket.

BATTERIES AND RECHARGE

Disposal of exhausted batteries

At the end of its useful life, a battery pack containing lithium batteries must be disposed of according to the Current Regulations and cannot be disposed of as simple waste.

The European Directive for this type of waste establishes that the States adhering to this convention undertake to adopt “appropriate measures” so that exhausted accumulators are collected separately, for the purpose of their possible recovery or disposal.

In any case, for more updated information on this topic, the user must contact the municipal office in charge of this concern.

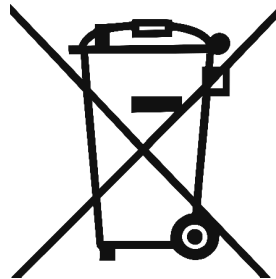

BATTERY CHARGER

Batteries are charged using the specific charger supplied (MOD. TVC202).

The charger is activated only when connected to the mains with its cable and to the vehicle or to a battery through the socket. Once connected, all leds will flash for a few seconds, and then indicate the remaining battery depending on the amount of leds lit.

The button **MODE** on the battery charger allows setting research mode choosing between:

MAINTENANCE: press **MODE** until 2 leds blink (up to 50), battery is charged until 50%. Now it is possible to leave the battery unused for longer periods while preserving battery life.

LONG LIFE (90% recharge): this mode is recommended in periods when the scooter is frequently used to obtain the best and prolonged operation of the batteries. For maximum system efficiency, it is recommended to alternate 1 100% charge cycle every 10 90% cycles.

This procedure allows to obtain a high number of charge and discharge cycles of the batteries, maintaining a good performance over time.

To select this mode press **MODE** until 4 leds start flashing (up to 90).

MAX. CHARGE: default mode, press **MODE** until 5 leds blink (up to 100), battery is charged until 100%. In this way there is maximum autonomy.

Charging time (eS_{pro} 45 - eS_{pro} 25Km/h): from 1 to 4 hours (full charge starting from low battery).

Charging time (eS_{pro} 70): from 1 to 6 hours (full charge starting from low battery).

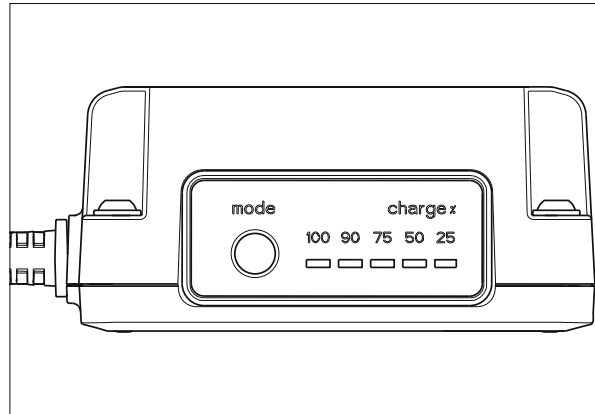

BATTERIES AND RECHARGE

 **CAUTION**

The charger is not intended to be used by persons with reduced physical, sensory or mental capacities, or lack of experience or knowledge, unless a person responsible for their safety has supervised or instructed them concerning the use of the charger. Keep the battery charger and batteries out of the reach of children, make sure that they do not play with the devices.

 **CAUTION**

Risk of electric shock

- This device is equipped with a 3-pole plug with grounding contact. Make sure that the power outlet has 3 pins and grounding contact. If not, contact an electrician to replace the outlet.
- Do not try to neutralize the grounding contact safety of the 3-pole plug.
- Connect the device to a power supply network protected by a differential switch with a sensitivity not exceeding 30mA.
- The electrical connection of the device must comply with the details on its electrical data label.
- Do not use extension cords. If the length of the power cord is not sufficient, consult an electrician or qualified installer.
- Do not cut or repair the power cord.
- The power cord of this device is of special type: if it is damaged it must be replaced by the manufacturer, or by its service centre or by an operator with similar qualification, in order to to avoid all risk.

 **CAUTION**

The battery chargers model TC202 and TC203 are intended to be used exclusively for charging batteries model TVC102 and TVC103 in indoor environments. Do not use the battery charger for purposes other than those specified.

CHARGING THE BATTERIES

Charge level of the batteries is shown on the left side of the digital display of the vehicle. On the display, the icon **A** indicates the charge of the battery housed in compartment **A**, icon **B** indicates the charge of the battery housed in compartment **B**. When battery charge level is close to 0% it is necessary to recharge.

Batteries can be recharged in two ways:

CHARGING WITH BATTERY ON BOARD

CHARGING WITH BATTERY OUTBOARD

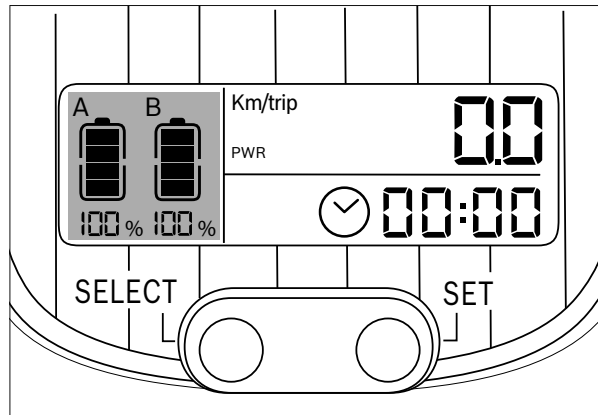

EN



Charging must be performed indoors and protected from the weather.



To recharge the batteries first connect the battery charging connector to the battery outlet and then connect the battery charger plug to the mains.

BATTERIES AND RECHARGE

CHARGING WITH BATTERY ON BOARD

To charge with battery on board:

Disable the system.

Raise the seat, make sure the charger is connected to the socket and that the batteries are properly inserted in their compartments and plugged to the connectors, pull out the battery charger spring wire equipped with plug.

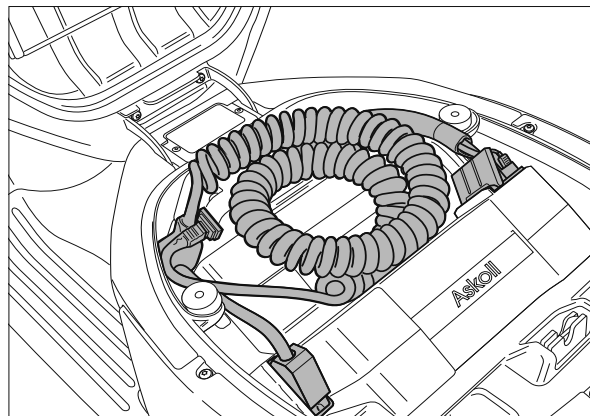

Connect the plug to the socket.

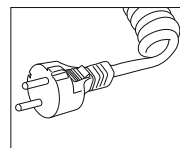

While charging, the amber light on the instrument panel will turn on and remain lit until the plug is removed from the mains.



Locking the seat in raised position for cable passage

While charging the battery on board you can close the seat using its lock while maintaining a sufficient opening for the charging cable.

This can be useful in case of outdoors charging so as to keep batteries and charger covered but allowing heat generated by the process to escape.

Open the seat, move the spring closing mechanism to the left and press.

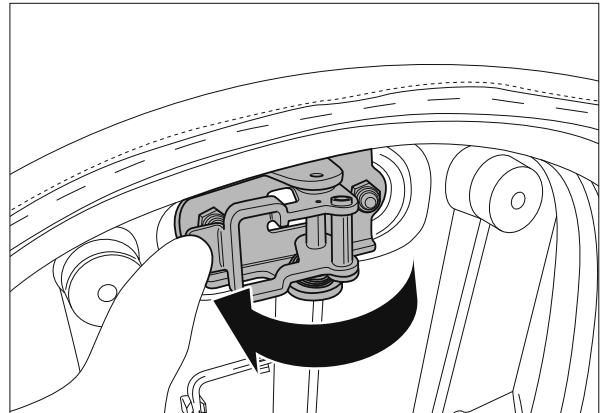
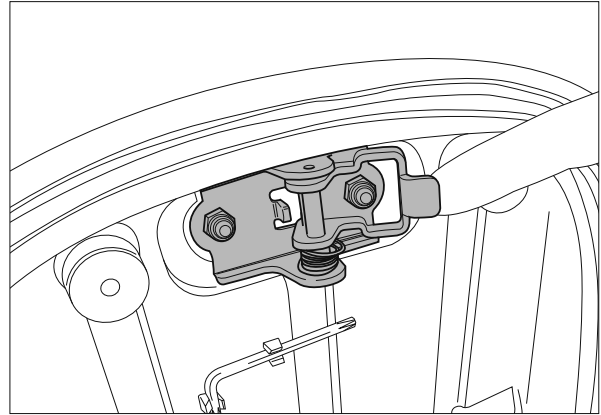

BATTERIES AND RECHARGE

Close the seat pressing the mechanism.

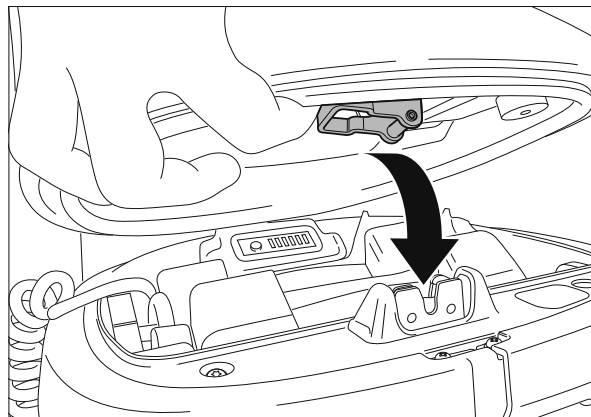

The seat is locked in raised position to allow the charging cable to pass.

Open the lock with the key and lift the seat to automatically return to its original position.

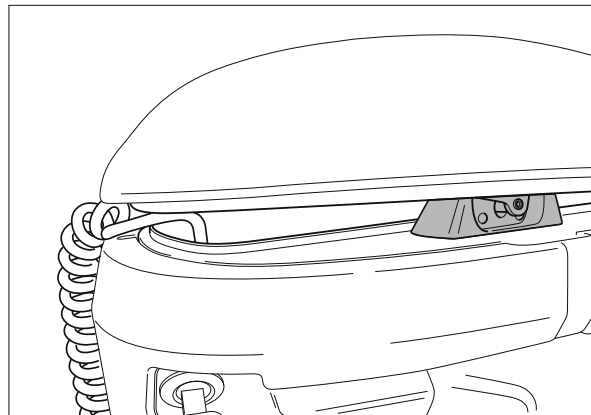

CHARGING WITH BATTERY OUTBOARD

The charger can be removed to allow charging a battery leaving the scooter the possibility to circulate only with the other one.

Disconnect the battery cable by pressing on the two side tabs of the connector and pull it out.

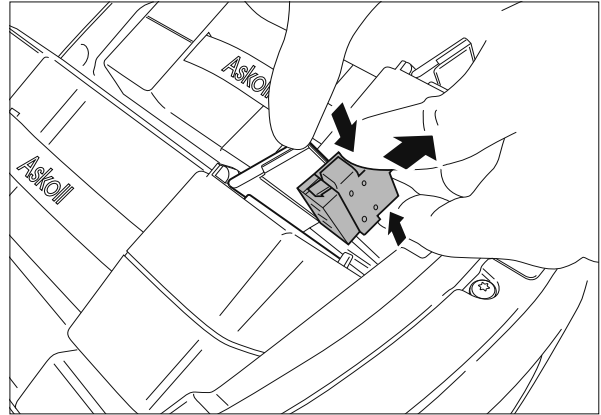

Remove the battery from the compartment using the lifting handle.

Once removed, hold it with both hands.

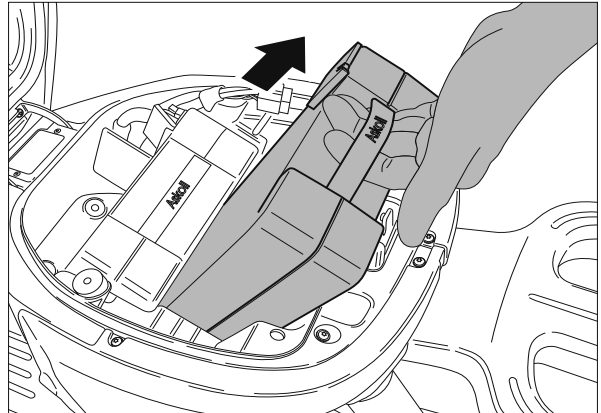

BATTERIES AND RECHARGE

Disconnect the charger cable from its socket, to remove it press the two side tabs.

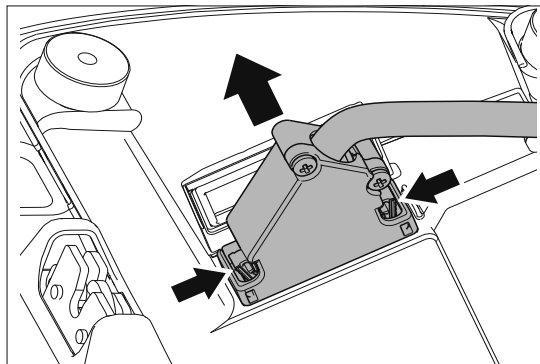

Remove the charger along with its two cables.

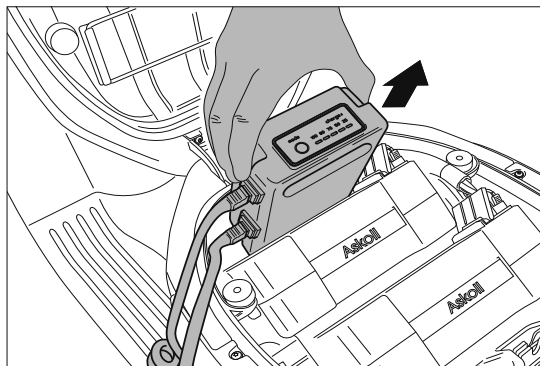

When removing the battery charger it is recommended to handle it with care to prevent it from falling on yourself or on the ground.

BATTERIES AND RECHARGE

Place battery and charger on a stable surface.

First, connect the charger cable to the battery socket under the spring flap. A “click” shows correct introduction.

Then connect the charger to the mains.

Select desired recharge mode, as shown in **“BATTERY CHARGER”**.

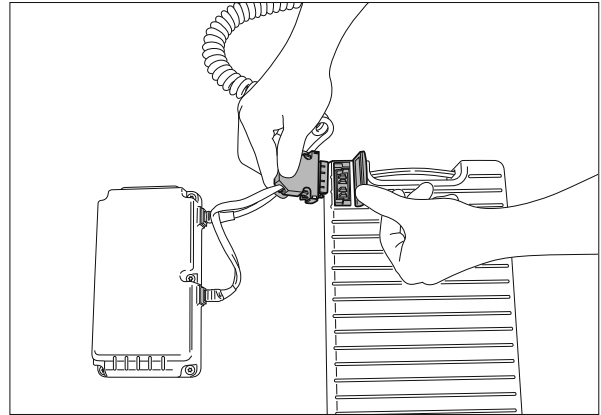

EN

Once charging has finished, place battery and charger in their compartment as follows:

First place the charger on the vehicle and connect the cable with connector to the vehicle socket.

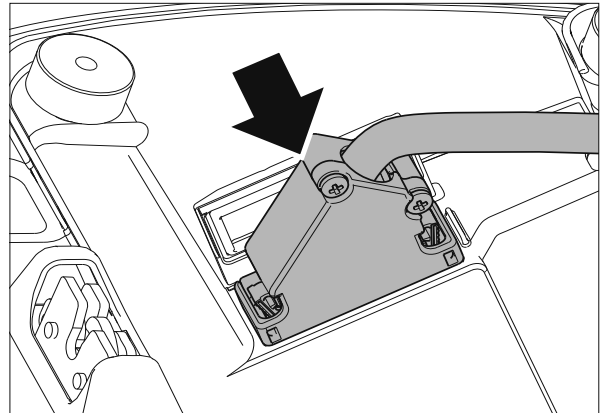

BATTERIES AND RECHARGE

Place the battery in its compartment holding it by the handle and plug the connector cable of the vehicle to the socket under the spring flap on the battery, insert the connector until you hear a “click” and make sure it is properly secured.

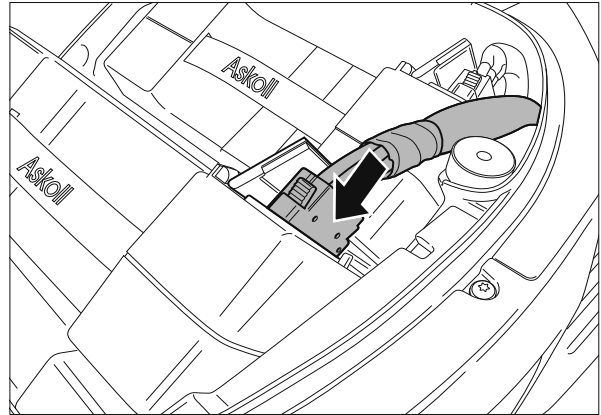

Then place the spring cable next to the battery charger and rewind the cable on top of the battery.

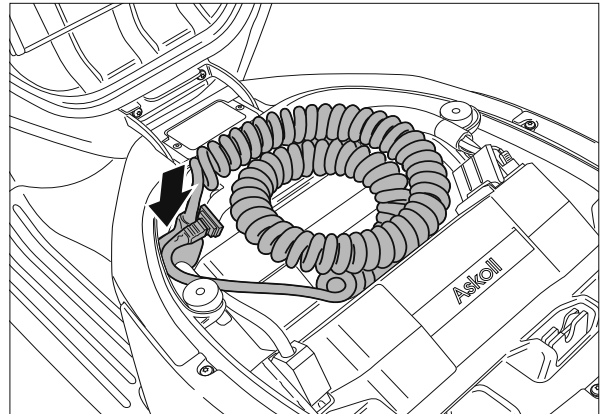

ADJUSTMENTS

REAR VIEW MIRRORS

On the right and left of the handlebar, two mirrors are mounted and can be adjusted manually by rotating the rod to the desired position.

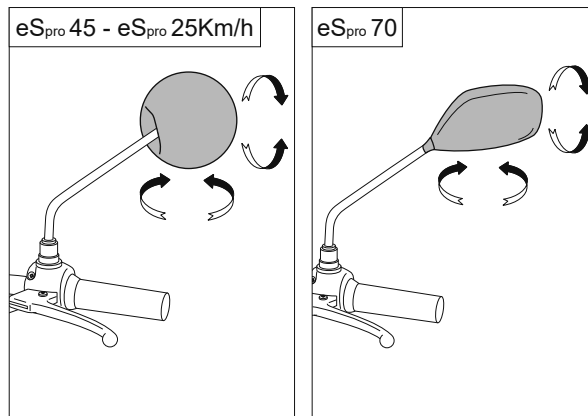

HEADLAMP

Headlamp light beam height can be adjusted by turning the adjustment screw under the lamp with **TORX T 20** wrench supplied as an accessory and placed under the seat.

By rotating the screw 1/2 turn clockwise, the light beam will point downwards while counterclockwise it will point upwards.

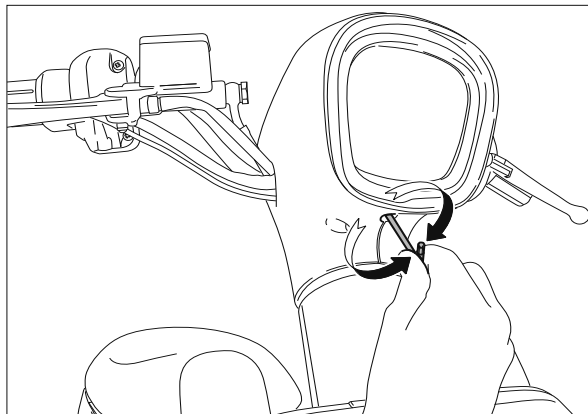

ADJUSTMENTS AND PERIODIC MAINTENANCE

FRONT DISC BRAKE

The wear of disc and pads is automatically compensated, therefore it has no effect on the operation of the brake and does not require registration.

If there is excessive stroke and the lever is too close to the grip when operating the brake, it could be due to the presence of air in the circuit or to irregular operation of the brake.

Effective braking action should begin after approximately 1/3 of the brake lever stroke.

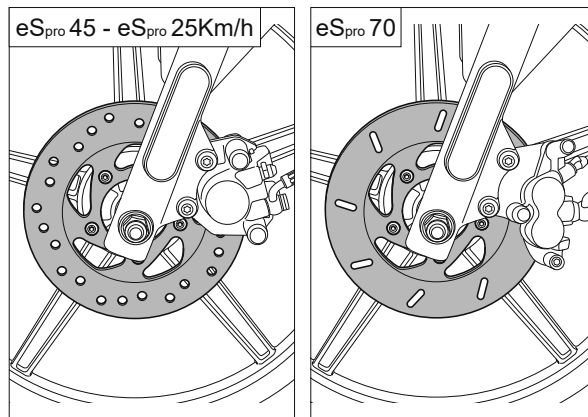

In case of brake malfunctions check brake pad wear, if thickness is reduced both are to be replaced at an authorized workshop.



After replacing the pads operate the brake lever several times to reposition them and bring the lever to the right position.

REAR BRAKE DRUM (eS_{pro} 45 - eS_{pro} 25Km/h)

To adjust rear brake act on the nut as shown.

Tightening the nut, free play of the control lever decreases and braking action increases.

Conversely, loosening the nut, free play of the control lever increases and braking action decreases. After adjustment, with the brake control lever in rest position, check that the wheel turns freely.

Effective braking action should begin after approximately 1/3 of the brake lever stroke.

REAR DRUM BRAKE WITH COMBINED FUNCTION (eS_{pro} 70 only)

The scooter model eS_{pro} 70 uses the dual braking: actuating the rear brake automatically also activates the front brake.

The distribution has prevalence on the rear and the adjustment of the rear adjusting nut affects both wheels.

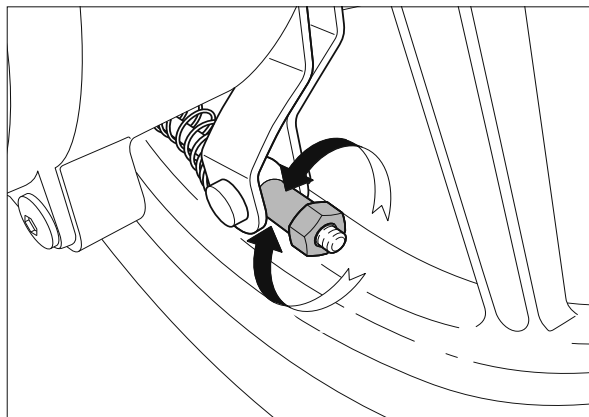

ADJUSTMENTS AND PERIODIC MAINTENANCE

ORDINARY MAINTENANCE PROCEDURES

TYRES

The vehicle is equipped with tubeless tires.

Regularly check tyre pressure and, if necessary, adjust it before riding.

eS_{pro} 45 - eS_{pro} 70 - eS_{pro} 25Km/h

Front tyre pressure 2,0 bar.

Rear tyre pressure 2,8 bar.

Tires have a wear indicator and must be changed as soon as these are visible on the tread.

Check also for cuts in the sides or irregular wear. In this case consult an authorized workshop for replacement.

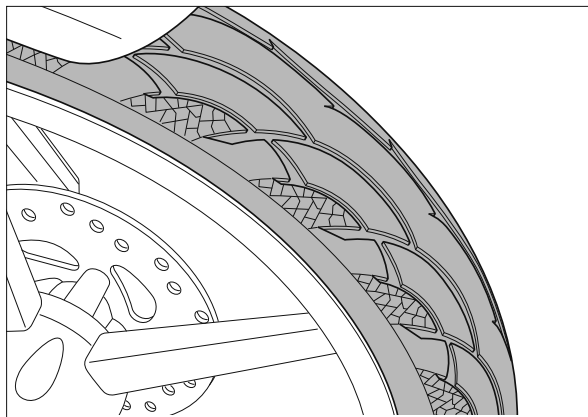

Always check tire pressure when cold, wrong pressure causes abnormal tire wear and makes driving dangerous.



Tires should be replaced when treads reach the wear limit provided by law.

ADJUSTMENTS AND PERIODIC MAINTENANCE

FRONT BRAKE FLUID LEVEL CONTROL

The front brake fluid reservoir is equipped with an inspection window to control the level in the tank.

If the brake fluid level is low or insufficient, **DO NOT** fill the tank but check the wear of pads and disc as well as for leaks in the braking circuit.

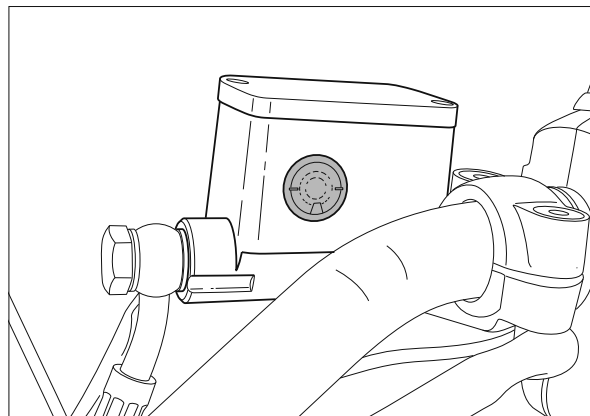

EN



Brake fluid is hygroscopic, i.e. it absorbs moisture from the surrounding air. If humidity in the fluid exceeds a certain value, braking will be inefficient.



It is advisable to change the fluid every 2 years, never use brake fluid from partially used or open containers.



Use only DOT4 brake fluid



Brake fluid is highly corrosive. Prevent it from being in contact with skin or with painted parts. In case of contact with skin, wash thoroughly with water.

ADJUSTMENTS AND PERIODIC MAINTENANCE

HEADLAMP BULB REPLACEMENT

(eS_{pro} 45 - eS_{pro} 25Km/h)

To replace the headlamp **H8 35W** bulb, use a supplied **TORX T 20** wrench (under the seat), remove the 2 lateral screws under the headlamp and then follow the procedure:

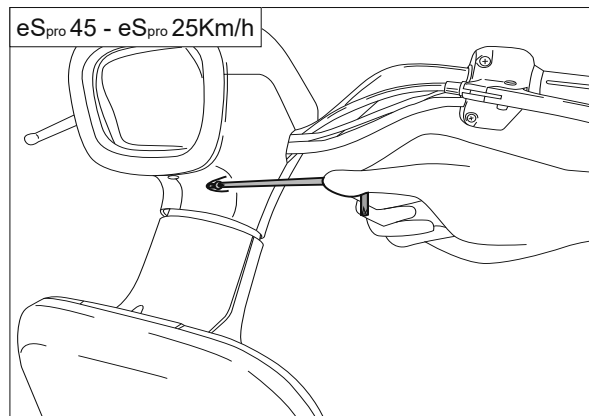

first remove the left half-shell and then the right one turning them outwards,

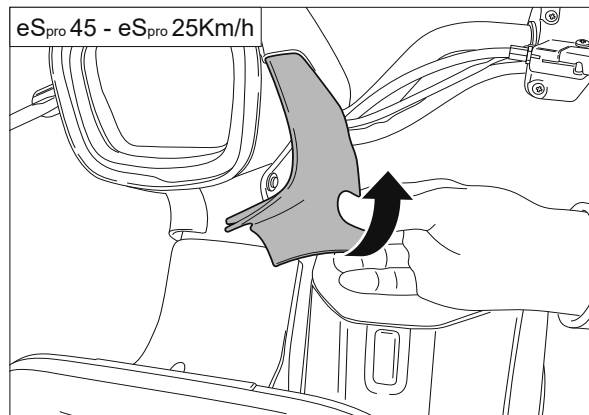

ADJUSTMENTS AND PERIODIC MAINTENANCE

disconnect the connector, turn the bulb holder anticlockwise and remove it.

Replace bulb and holder with a new one.

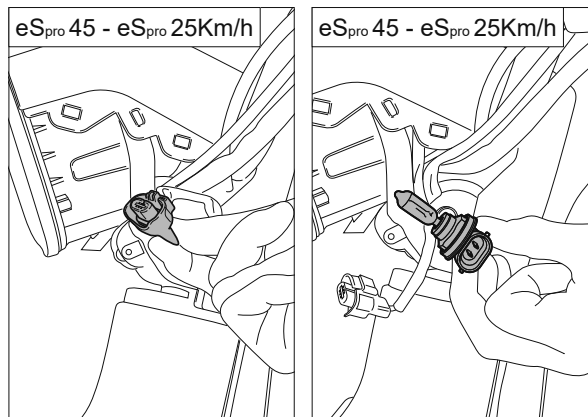

EN

HEADLIGHT (eS_{pro} 70)

In the scooter model eS_{pro} 70 the headlight is equipped with an LED lamp and there is no need to replace it.

If the bulb is exhausted it is necessary to change the complete headlight.

For the replacement, contact an authorized service point.

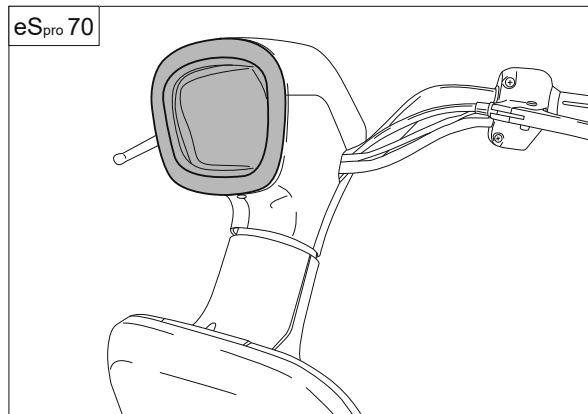

ADJUSTMENTS AND PERIODIC MAINTENANCE

TAIL LIGHTS AND TURN INDICATORS

The tail light, front and rear turn indicators and number plate light are equipped with LEDs and are integrated to the vehicle structure.

To replace them contact an authorized workshop.

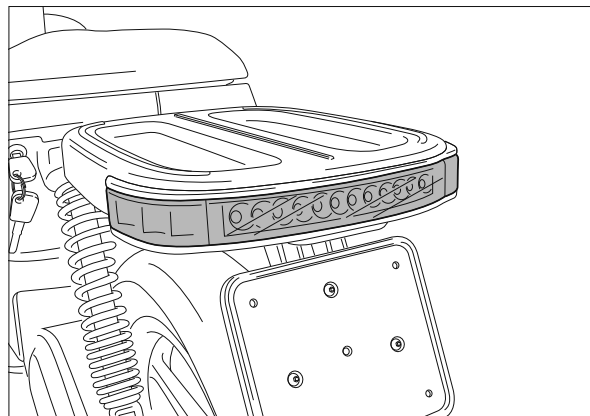

ADJUSTMENTS AND PERIODIC MAINTENANCE

ORDINARY MAINTENANCE PROCEDURES TABLE

C: clean; R: adjust; L: lubricate; S: replace

YEARS	1	2	3	4	5	6	7	8	9	10
Km x 1,000	1	4	8	12	16	20	24	28	32	36
Headlamp orientation		C/R	C/R	C/R	C/R	C/R	C/R	C/R	C/R	C/R
Front brake fluid (replace every 2 years)		S		S		S		S		S
Front brake pad wear		C	S	C	S	C	S	C	S	C
Rear brake shoe wear		C/R		C/S		C/S		C/S		C/S
Transmission belts	C	C	C/S	C	C/S	C	C/S	C	C/S	C
Nuts, bolts, fasteners	C	C		C		C		C		C
Stand		C/L		C/L		C/L		C/L		C/L
Steering bearings	C			C			C			C

Except for "Headlamp orientation" all checks must be carried out by qualified personnel from ASKOLL.

EN

ADJUSTMENTS AND PERIODIC MAINTENANCE





CLEANING THE VEHICLE

To avoid oxidation, wash the scooter every time it is used in extreme weather conditions or roads sprinkled with salt or de-icing products, conditions of air pollution such as cities, industrial zones, areas of high salinity or moisture in the atmosphere such as maritime areas.

Keep the frame clean from long-accumulated dirt, residues of industrial dust, dead insects, bird droppings, etc.

Use a low pressure water jet to soften dirt accumulated on the paintwork, then remove it with a soft sponge soaked with abundant water and shampoo, rinse and dry with a suede.

Avoid washing the scooter under direct sunlight, especially in summer, to prevent it from drying and warming the shampoo immediately before rinsing since this may damage the paint.

	Do not use high pressure water jets to washing, so as to prevent damaging delicate components of the vehicle.
	When washing do not direct the water jet directly on delicate components such as electrical wiring or their connections.
	Never use rags soaked in gasoline, alcohol or potentially corrosive liquids to wash painted surfaces, plastic or the seat to avoid loss of gloss and mechanical properties of the materials, or even damaging them.
	The scooter must be washed in areas equipped for collecting and purifying the liquid used.

VEHICLE INACTIVITY

In preparation for a long period of inactivity it is advisable to:

- make a general clean up of the scooter,
- store in a covered place,
- park the scooter on the stand so that wheels are not in contact with the ground in the same position.
- cover the scooter with a canvas.

ERROR CODES

ERROR CODES

Communication system failure: detection of communication problems between intelligent units. It is advisable to take the vehicle to an authorized workshop.

Inverter failure: the system detects a failure on the inverter. It is advisable to take the vehicle to an authorized workshop.

ECU failure: the system detects a failure on the ECU. It is advisable to take the vehicle to an authorized workshop.

Power circuit failure: the system detects an abnormal absorption by the engine. For safety reasons, the system does not supply power. It is advisable to take the vehicle to an authorized workshop.

Battery A failure: the system detects a failure on battery A. It is advisable to take the battery to an authorized workshop.

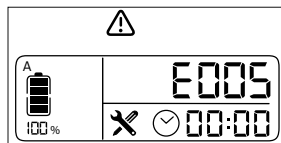
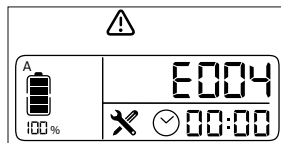
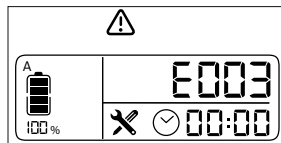
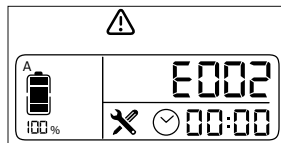
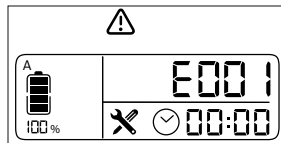

Battery B failure: the system detects a failure on battery B. It is advisable to take the battery to an authorized workshop.

Battery overtemperature: the system detects excessive temperature on the batteries and inhibits the supply power. Remove the vehicle from places with high temperature and wait for the batteries to cool down.

Inverter overtemperature: the system detects excessive temperature on the electronic unit. The system does not supply power until the temperature drops. Remove the vehicle from sources of heat.

Engine overtemperature: the system detects excessive temperature on the engine. It can function at reduced power to allow cooling.

Headlight malfunction: the system detects the failure or malfunction of the front lamp. Check its operation and replace it at an authorized workshop.

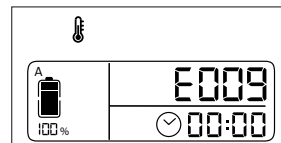
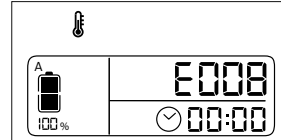
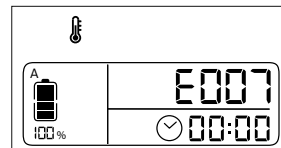
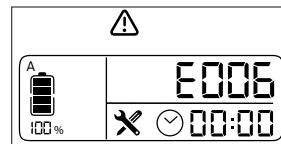

ERROR CODES

Turn indicators malfunction: the system detects the failure or malfunction of the turn indicators. Check its operation and replace them at an authorized workshop.

Tail light and number plate light malfunction: the system detects the failure or malfunction of the Tail light and number plate light. Check its operation and replace them at an authorized workshop.

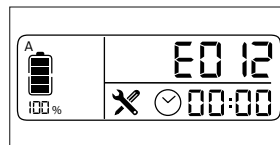

SCOOTER DIMENSIONS eS_{pro} 45 - eS_{pro} 70 - eS_{pro} 25Km/h

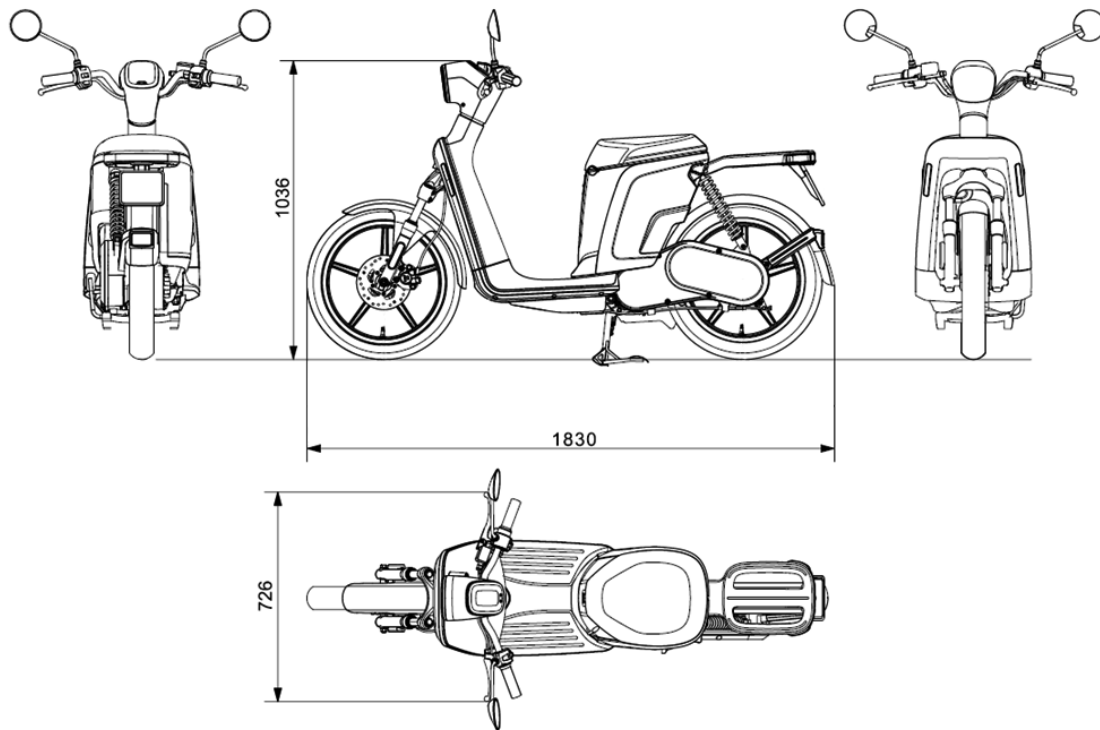

EN

TECHNICAL DATA

MODEL	eS _{pro} 45	eS _{pro} 25Km/h	eS _{pro} 70
ENGINE DATA			
Model	Brushless permanent magnet sinusoidal motor		
Motor type	EME 200		EME 201
Operating voltage	54 V		
MAX power	3 KW electronically limited * with 2 batteries connected and with the same charging value	1,4 KW electronically limited	3 KW electronically limited * with 2 batteries connected and with the same charging value according to 168/2013 EC

BATTERY			
Model	TVC102		TVC103
Charge	LI - ION		
Weight	7,8 Kg		
Autonomy	71 Km * with 2 batteries connected and with the same charging value according to 168/2013 EC	86 Km * with 2 batteries connected and with the same charging value according to 168/2013 EC	96 Km * with 2 batteries connected and with the same charging value according to 168/2013 EC
Operation temperature	When operating -20 °C to +45 °C		

VEHICLE DATA		
Long	1830 mm	
Wide	726 mm	
Wheelbase	1245 mm	
Rearview mirror connection height	1036 mm	

MODEL	eS _{pro} 45	eS _{pro} 25Km/h	eS _{pro} 70
VEHICLE DATA			
Front tire pressure	2 bar		
Rear tire pressure	2,8 bar		
Net weight	77 Kg		
Max. weight	245 Kg (vehicle + driver + additional load)		
Maximum permissible weight on the rear carrier luggage rack	30Kg centered on the luggage rack		
Seats	1		
Transmission	Toothed belt		

HEADLIGHT DATA			
Headlight	H8 35W		LED
Turn indicators	LED		
Dashboard lights	LED		

TAIL LIGHT DATA			
Taillight	LED		
Brake light	LED		
Turn indicators	LED		
License plate light	LED		

DECLARATION OF CONFORMITY



The undersigned		
name:	Elio Marioni	
legal representative of the		
manufacturer:	Askoll EVA Srl	
address:	Via Industria, 30 36031 DUEVILLE VI – Italy	
herewith declares that the product		
description:	Battery chargers for electric scooters	
model:	TVC202	
complies with the provisions of the following Directives (including all applicable amendments)		
	Directive 2014/35/EU (and Directive 2006/95/CE)	
	Directive 2014/30/EU (and Directive 2004/108/CE)	
	Directive 2011/65/EU	
and all the following standards and / or technical specifications have been applied		
	EN 60335-1; EN 60335-2-29	
	EN 61000-3-2; EN 61000-3-3; EN 55014-1; EN 55014-2	
	EN 62223	
	EN 50581	
Place	Date	Signature
Dueville	January 1, 2016	

Askoll EVA Spa
Via Industria, 30
36031 Dueville (VI) Italia
Tel. 0444 930260
www.askollelectric.com